



LINEAR INEQUALITIES



LEARNING OBJECTIVES

One of the widely used decision making problems, nowadays, is to decide on the optimal mix of scarce resources in meeting the desired goal. In simplest form, it uses several linear inequations in two variables derived from the description of the problem.

The objective in this section is to make a foundation of the working methodology for the above by way of introduction of the idea of :

- ◆ development of inequations from the descriptive problem;
- ◆ graphing of linear inequations; and
- ◆ determination of common region satisfying the inequations.

CHAPTER OVERVIEW

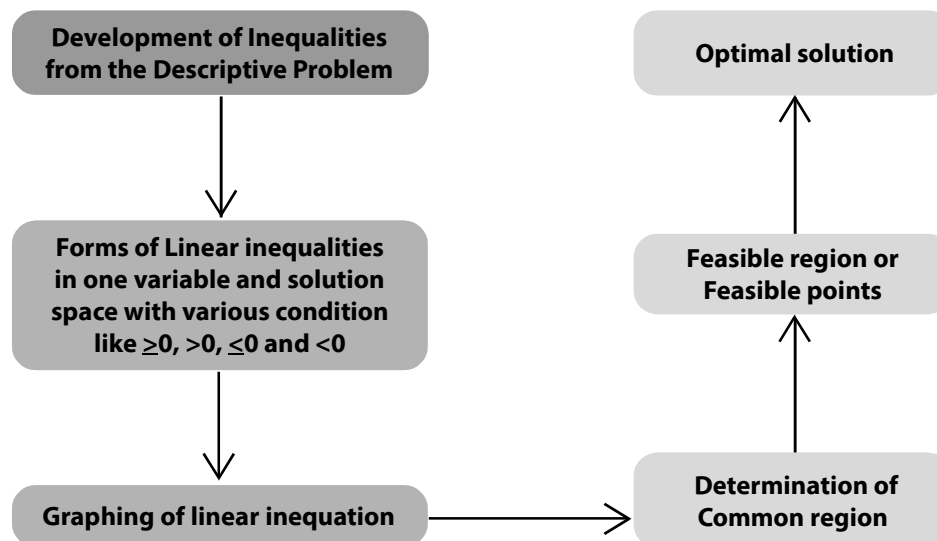

3.1 INEQUALITIES

Inequalities are statements where two quantities are unequal but a relationship exists between them. These type of inequalities occur in business whenever there is a limit on supply, demand, sales etc. For example, if a producer requires a certain type of raw material for his factory and there is an upper limit in the availability of that raw material, then any decision which he takes about production should involve this constraint also. We will see in this chapter more about such situations.

3.2 LINEAR INEQUALITIES IN ONE VARIABLE AND THE SOLUTION SPACE

Any linear function that involves an inequality sign is a linear inequality. It may be of one variable, or, of more than one variable. Simple example of linear inequalities are those of one variable only; viz., $x > 0$, $x \leq 0$ etc.



The values of the variables that satisfy an inequality are called the *solution space*, and is abbreviated as S.S. The solution spaces for (i) $x > 0$, (ii) $x \leq 0$ are shaded in the above diagrams, by using deep lines.

Linear inequalities in two variables: Now we turn to linear inequalities in two variables x and y and shade a few S.S.

Let us now consider a linear inequality in two variables given by $3x + y < 6$

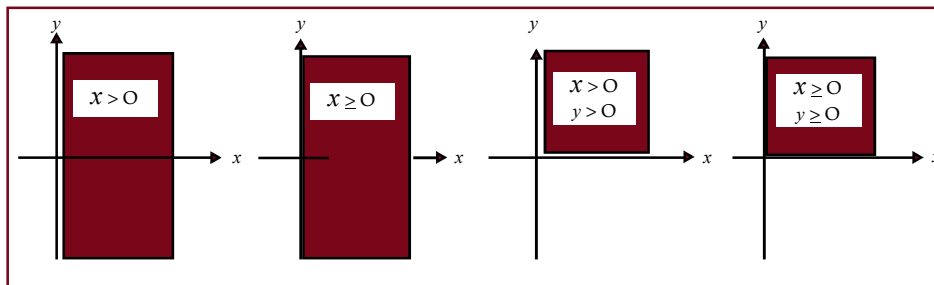

The inequality mentioned above is true for certain pairs of numbers (x, y) that satisfy $3x + y < 6$. By trial, we may arbitrarily find such a pair to be $(1, 1)$ because $3 \times 1 + 1 = 4$, and $4 < 6$.

Linear inequalities in two variables may be solved easily by extending our knowledge of straight lines.

For this purpose, we replace the inequality by an equality and seek the pairs of number that satisfy $3x + y = 6$. We may write $3x + y = 6$ as $y = 6 - 3x$, and draw the graph of this linear

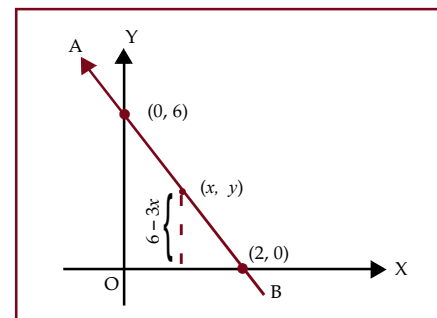

function.

Let $x = 0$ so that $y = 6$. Let $y = 0$, so that $x = 2$.

Any pair of numbers (x, y) that satisfies the equation $y = 6 - 3x$ falls on the line AB.

Note: The pair of inequalities $x \geq 0, y \geq 0$ play an important role in linear programming problems.

Therefore, if y is to be less than $6 - 3x$ for the same value of x , it must assume a value that is less than the ordinate of length $6 - 3x$.

All such points (x, y) for which the ordinate is less than $6 - 3x$ lie below the line AB.

The region where these points fall is indicated by an arrow and is shaded too in the adjoining diagram. Now we consider two inequalities $3x + y \leq 6$ and $x - y \leq -2$ being satisfied simultaneously by x and y . The pairs of numbers (x, y) that satisfy both the inequalities may be found by drawing the graphs of the two lines $y = 6 - 3x$ and $y = 2 + x$, and determining the region where both the inequalities hold. It is convenient to express each equality with y on the left-side and the remaining terms in the right side. The first inequality $3x + y \leq 6$ is equivalent to $y \leq 6 - 3x$ and it requires the value of y for each x to be less than or equal to that of and on $6 - 3x$. The inequality is therefore satisfied by all points lying below the line $y = 6 - 3x$. The region where these points fall has been shaded in the adjoining diagram.

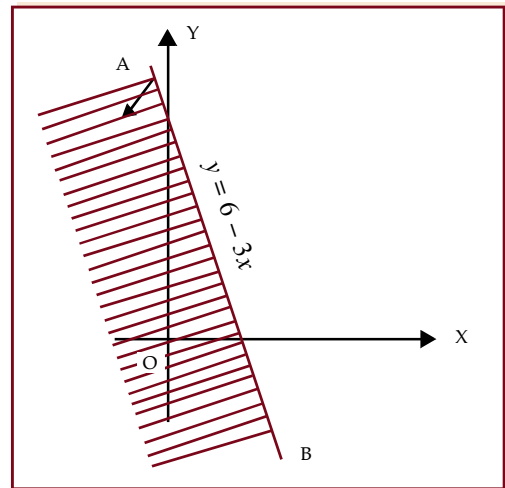

We consider the second inequality $x - y \leq -2$, and note that this is equivalent to $y \geq 2 + x$. It requires the value of y for each x to be larger than or equal to that of $2 + x$. The inequality is, therefore, satisfied by all points lying on and above the line $y = 2 + x$.

The region of interest is indicated by an arrow on the line $y = 2 + x$ in the diagram below.

For $x = 0, y = 2 + 0 = 2$;

For $y = 0, 0 = 2 + x$ i.e, $x = -2$.

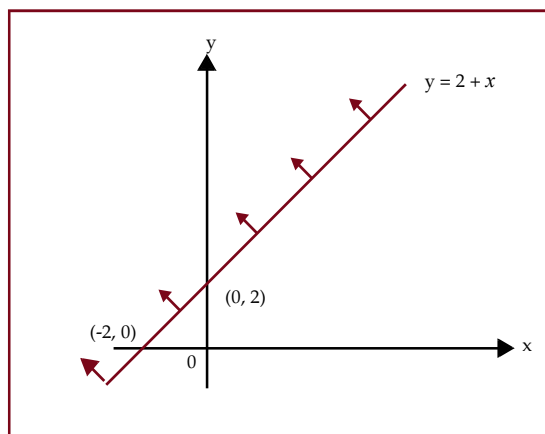

By superimposing the above two graphs we determine the common region ACD in which the pairs (x, y) satisfy both inequalities.

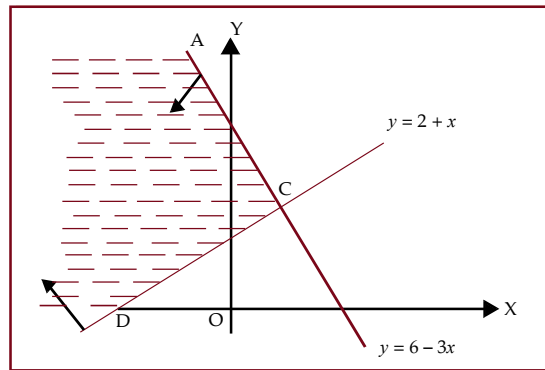

Example 1: We now consider the problem of drawing graphs of the following inequalities

$$x \geq 0, y \geq 0, x \leq 6, y \leq 7, x + y \leq 12$$

and shading the common region.

Note: [1] The inequalities $3x + y \leq 6$ and $x - y \leq -2$ differ from the preceding ones in that these also include equality signs. It means that the points lying on the corresponding lines are also included in the region.

[2] The procedure may be extended to any number of inequalities.

We note that the given inequalities may be grouped as follows :

$$x \geq 0, \quad y \geq 0$$

$$x \leq 6, \quad y \leq 7, \quad x + y \leq 12$$

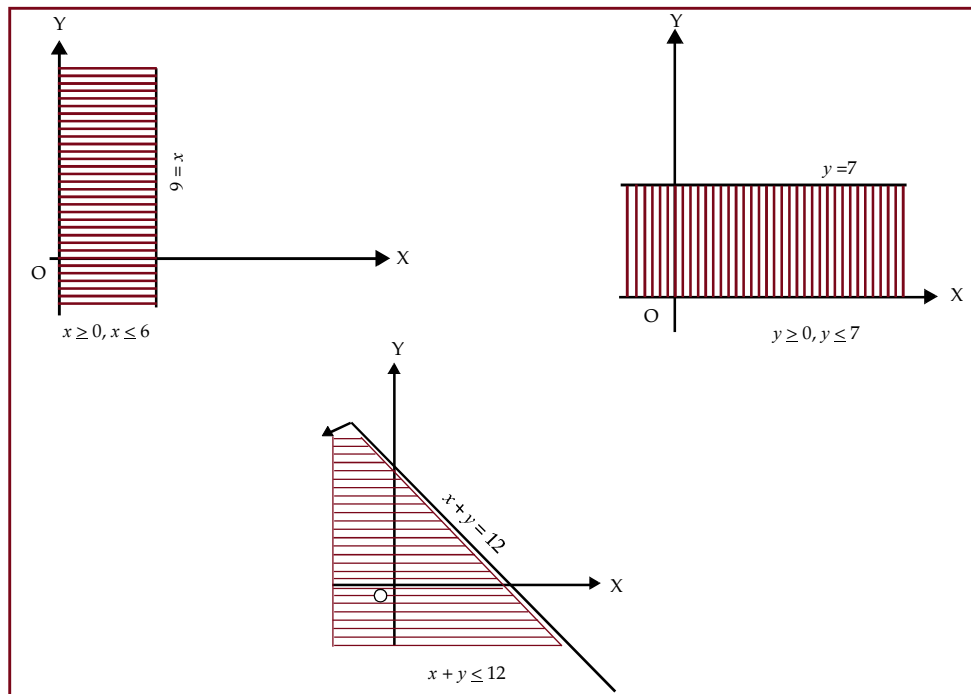

By superimposing the above three graphs, we determine the common region in the xy plane where all the five inequalities are simultaneously satisfied.

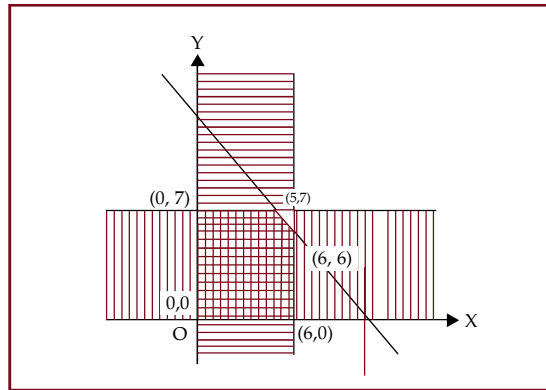

This common region is known as feasible region or the solution set (or the polygonal convex sets).

A region is said to be *bounded* if it can be totally included within a (very large) circle. The shaded region enclosed by deep lines in the previous diagram is bounded, since it can be included within a circle.

The objective function attains a maximum or a minimum value at one of the corner points of the feasible solution known as extreme points of the solution set. Once these extreme points (the points of intersection of lines bounding the region) are known, a compact matrix representation of these points is possible. We shall denote the matrix of the extreme points by E .

The coefficients of the objective function may also be represented by a column vector. We shall represent this column vector by C .

The elements in the product matrix EC shows different values, which the objective function attains at the various extreme points. The largest and the smallest elements in matrix EC are respectively the maximum and the minimum values of the objective function. The row in matrix EC in which this happens is noted and the elements in that row indicate the appropriate pairing and is known as the *optimal solution*.

In the context of the problem under consideration.

$$E = \begin{matrix} X & Y \\ \begin{bmatrix} 0 & 0 \\ 0 & 7 \\ 5 & 7 \\ 6 & 0 \\ 6 & 6 \end{bmatrix} \end{matrix}, C = \begin{bmatrix} 1 \\ 2 \end{bmatrix} \begin{matrix} x \\ y \end{matrix}$$

$$EC = \begin{bmatrix} 0 & 0 \\ 0 & 7 \\ 5 & 7 \\ 6 & 0 \\ 6 & 6 \end{bmatrix} \begin{bmatrix} 1 \\ 2 \end{bmatrix} = \begin{bmatrix} 0 \times 1 + 0 \times 2 \\ 0 \times 1 + 7 \times 2 \\ 5 \times 1 + 7 \times 2 \\ 6 \times 1 + 0 \times 2 \\ 6 \times 1 + 6 \times 2 \end{bmatrix} = \begin{bmatrix} 0 \\ 14 \\ 19 \\ 6 \\ 18 \end{bmatrix}$$

The given objective function viz. $Z = x + 2y$ is maximum at the points (5, 7) present in the third row of the matrix E. Thus the optimal solution is $x = 5$, $y = 7$, and the maximum value of the objective function is 19.

We now list the steps to be followed under graphical solution to a linear programming problem.

- Step 1** Determine the region that satisfies the set of given inequalities.
- Step 2** Ensure that the region is bounded*. If the region is not bounded, either there are additional hidden conditions which can be used to bound the region or there is no solution to the problem.
- Step 3** Construct the matrix E of the extreme points, and the column vector C of the objective function.
- Step 4** Find the matrix product EC. For maximization, determine the row in EC where the largest element appears; while for minimization, determine the row in EC where the smallest element appears.
- Step 5** The objective function is optimized corresponding to the same row elements of the extreme point matrix E.

Note: If the slope of the objective function be same as that of one side of feasible region, there are multiple solutions to the problem. However, the optimized value of the objective function remains the same.

Example 2:

A manufacturer produces two products A and B, and has his machines in operation for 24 hours a day. Production of A requires 2 hours of processing in machine M_1 and 6 hours in machine M_2 . Production of B requires 6 hours of processing in machine M_1 and 2 hours in machine M_2 . The manufacturer earns a profit of ₹ 5 on each unit of A and ₹ 2 on each unit of B. How many units of each product should be produced in a day in order to achieve maximum profit?

Solution:

Let x_1 be the number of units of type A product to be produced, and x_2 is that of type B product to be produced. The formulation of the L.P.P. in this case is as below:

$$\text{Maximize } Z = 5x_1 + 2x_2$$

* It is inconceivable for a practical problem to have an unbounded solution.

subject to the constraints.

$$2x_1 + 6x_2 < 24$$

$$6x_1 + 2x_2 < 24$$

$$x_1 \geq 0, x_2 \geq 0$$

For the line $2x_1 + 6x_2 = 24$

Let $x_1 = 0$, so that $x_2 = 4$

Let $x_2 = 0$, so that $x_1 = 12$

For the line $6x_1 + 2x_2 = 24$

Let $x_1 = 0$, so that $x_2 = 12$

Let $x_2 = 0$, so that $x_1 = 4$

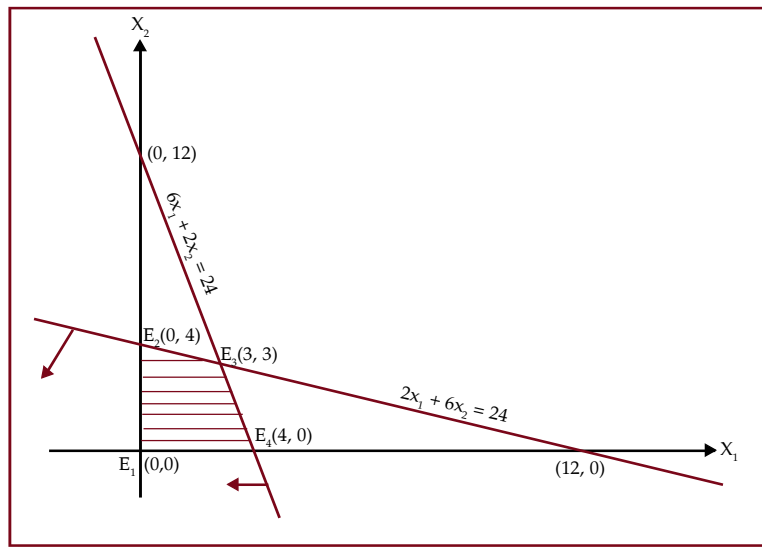

The shaded portion in the diagram is the feasible region and the matrix of the extreme points E_1, E_2, E_3 and E_4 is

$$E = \begin{array}{c} X_1 \quad Y_2 \\ \begin{bmatrix} 0 & 0 \\ 0 & 4 \\ 3 & 3 \\ 4 & 0 \end{bmatrix} \begin{array}{l} E_1 \\ E_2 \\ E_3 \\ E_4 \end{array} \end{array}$$

The column vector for the objective function is $C = \begin{bmatrix} 5 \\ 2 \end{bmatrix}$ $\begin{matrix} x_1 \\ x_2 \end{matrix}$

The column vector the values of the objective function is given by

$$EC = \begin{bmatrix} 0 & 0 \\ 0 & 4 \\ 3 & 3 \\ 4 & 0 \end{bmatrix} \begin{bmatrix} 5 \\ 2 \end{bmatrix} = \begin{bmatrix} 0 \times 5 + 0 \times 2 \\ 0 \times 5 + 4 \times 2 \\ 3 \times 5 + 3 \times 2 \\ 4 \times 5 + 0 \times 2 \end{bmatrix} = \begin{bmatrix} 0 \\ 8 \\ 21 \\ 20 \end{bmatrix} \begin{matrix} E_1 \\ E_2 \\ E_3 \\ E_4 \end{matrix}$$

Since 21 is the largest element in matrix EC, therefore the maximum value is reached at the extreme point E_3 whose coordinates are (3,3).

Thus, to achieve maximum profit the manufacturer should produce 3 units each of both the products A and B.

Summary of Graphical Method

It involves:

- (i) Formulating the linear programming problem, i.e. expressing the objective function and constraints in the standardised format.
- (ii) Plotting the capacity constraints on the graph paper. For this purpose normally two terminal points are required. This is done by presuming simultaneously that one of the constraints is zero. When constraints concerns only one factor, then line will have only one origin point and it will run parallel to the other axis.
- (iii) Identifying feasible region and coordinates of corner points. Mostly it is done by breading the graph, but a point can be identified by solving simultaneous equation relating to two lines which intersect to form a point on graph.
- (iv) Testing the corner point which gives maximum profit. For this purpose the coordinates relating to the corner point should put in objectives function and the optimal point should be ascertained.
- (v) For decision – making purpose, sometimes, it is required to know whether optimal point leaves some resources unutilized. For this purpose value of coordinates at the optimal point should be put with constraint to find out which constraints are not fully utilized.

Example 3: A company produces two products A and B, each of which requires processing in two machines. The first machine can be used at most for 60 hours, the second machine can be used at most for 40 hours. The product A requires 2 hours on machine one and one hour on machine two. The product B requires one hour on machine one and two hours on machine two. Express above situation using linear inequalities.

Solution: Let the company produce, x number of product A and y number of product B. As each of product A requires 2 hours in machine one and one hour in machine two, x number of product A requires $2x$ hours in machine one and x hours in machine two. Similarly, y number of product

B requires y hours in machine one and $2y$ hours in machine two. But machine one can be used for 60 hours and machine two for 40 hours. Hence $2x + y$ cannot exceed 60 and $x + 2y$ cannot exceed 40. In other words,

$$2x + y \leq 60 \quad \text{and} \quad x + 2y \leq 40.$$

Thus, the conditions can be expressed using linear inequalities.

Example 4: A fertilizer company produces two types of fertilizers called grade I and grade II. Each of these types is processed through two critical chemical plant units. Plant A has maximum of 120 hours available in a week and plant B has maximum of 180 hours available in a week. Manufacturing one bag of grade I fertilizer requires 6 hours in plant A and 4 hours in plant B. Manufacturing one bag of grade II fertilizer requires 3 hours in plant A and 10 hours in plant B. Express this using linear inequalities.

Solution: Let us denote by x_1 , the number of bags of fertilizers of grade I and by x_2 , the number of bags of fertilizers of grade II produced in a week. We are given that grade I fertilizer requires 6 hours in plant A and grade II fertilizer requires 3 hours in plant A and plant A has maximum of 120 hours available in a week. Thus $6x_1 + 3x_2 \leq 120$.

Similarly grade I fertilizer requires 4 hours in plant B and grade II fertilizer requires 10 hours in Plant B and Plant B has maximum of 180 hours available in a week. Hence, we get the inequality $4x_1 + 10x_2 \leq 180$.

Example 5: Graph the inequalities $5x_1 + 4x_2 \geq 9$, $x_1 + x_2 \geq 3$, $x_1 \geq 0$ and $x_2 \geq 0$ and mark the common region.

Solution: We draw the straight lines $5x_1 + 4x_2 = 9$ and $x_1 + x_2 = 3$.

Table for $5x_1 + 4x_2 = 9$

x_1	0	$9/5$
x_2	$9/4$	0

Table for $x_1 + x_2 = 3$

x_1	0	3
x_2	3	0

Now, if we take the point (4, 4), we find

$$5x_1 + 4x_2 \geq 9$$

i.e., $5 \cdot 4 + 4 \cdot 4 \geq 9$

or, $36 \geq 9$ (True)

$$x_1 + x_2 \geq 3$$

i.e., $4 + 4 \geq 3$

$$8 \geq 3 \text{ (True)}$$

Hence (4, 4) is in the region which satisfies the inequalities.

We mark the region being satisfied by the inequalities and note that the cross-hatched region is satisfied by all the inequalities.

Example 6: Draw the graph of the solution set of the following inequality and equality:

$$x + 2y = 4.$$

$$x - y \leq 3.$$

Mark the common region.

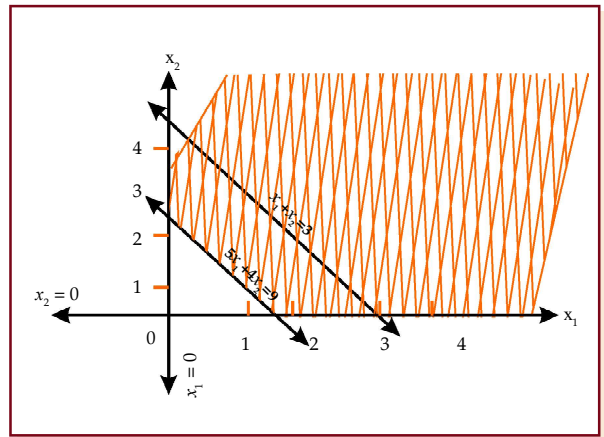

Solution: We draw the graph of both $x + 2y = 4$ and $x - y \leq 3$ in the same plane.

The solution set of system is that portion of the graph of $x + 2y = 4$ that lies within the half-plane representing the inequality $x - y \leq 3$.

For $x + 2y = 4$,

x	4	0
y	0	2

For $x - y = 3$,

x	3	0
y	0	-3

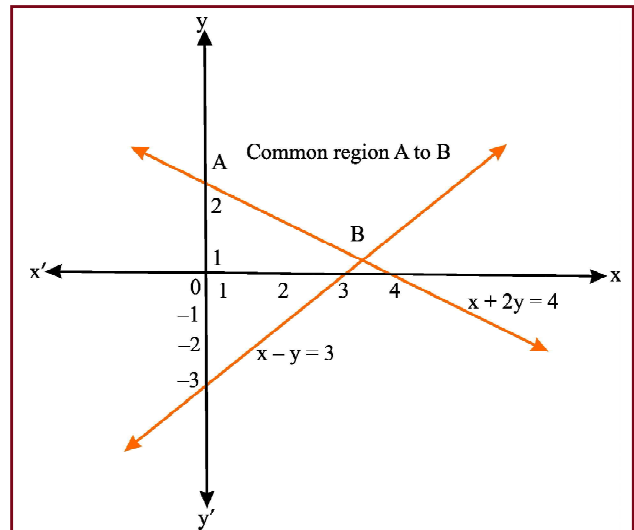

Example 7: Draw the graphs of the following inequalities:

$$x + y \leq 4,$$

$$x - y \leq 4,$$

$$x \geq -2.$$

and mark the common region.

For $x - y = 4$,

x	4	0
y	0	-4

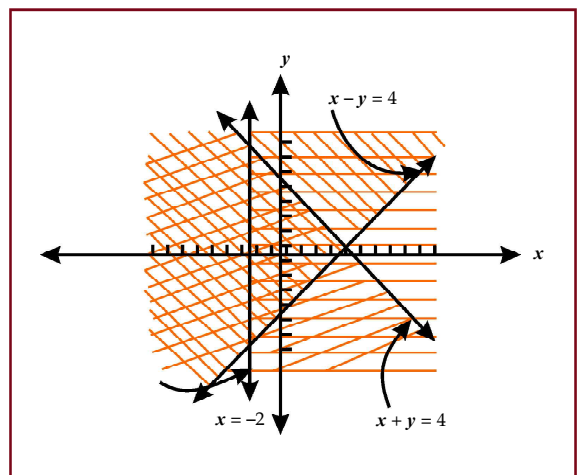

For $x + y = 4$,

x	0	4
y	4	0

The common region is the one represented by overlapping of the shadings.

Example 8: Draw the graphs of the following linear inequalities:

$$5x + 4y \leq 100, \quad 5x + y \geq 40,$$

$$3x + 5y \leq 75, \quad x \geq 0, y \geq 0.$$

and mark the common region.

Solution:

$$5x + 4y = 100 \quad \text{or,} \quad \frac{x}{20} + \frac{y}{25} = 1$$

$$3x + 5y = 75 \quad \text{or,} \quad \frac{x}{25} + \frac{y}{15} = 1$$

$$5x + y = 40 \quad \text{or,} \quad \frac{x}{8} + \frac{y}{40} = 1$$

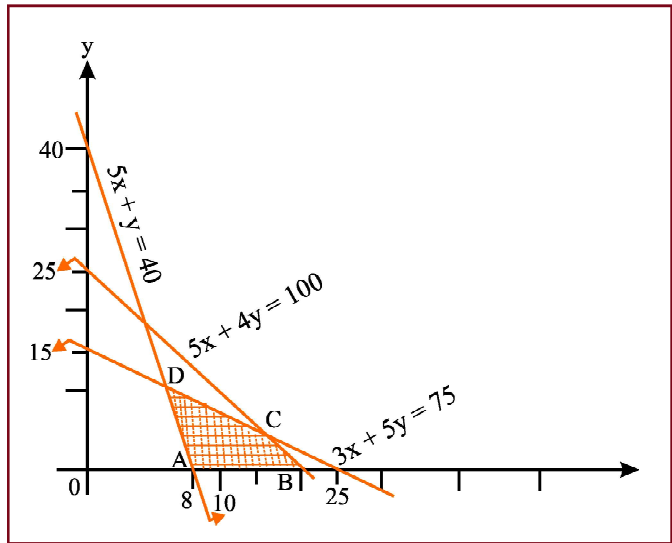

Plotting the straight lines on the graph paper we have the above diagram:

The common region of the given inequalities is shown by the shaded portion ABCD.

Example 9: Draw the graphs of the following linear inequalities:

$$5x + 8y \leq 2000, \quad x \leq 175, \quad x \geq 0,$$

$$7x + 4y \leq 1400, \quad y \leq 225, \quad y \geq 0.$$

and mark the common region:

Solution: Let us plot the line AB ($5x + 8y = 2,000$) by joining the points A(400, 0) and B(0, 250).

x	400	0
y	0	250

Similarly, we plot the line CD ($7x + 4y = 1400$) by joining the points C(200, 0) and D(0, 350).

x	200	0
y	0	350

Also, we draw the lines $EF(x = 175)$
and $GH(y = 225)$.
The required graph is shown alongside
in which the common region is shaded.

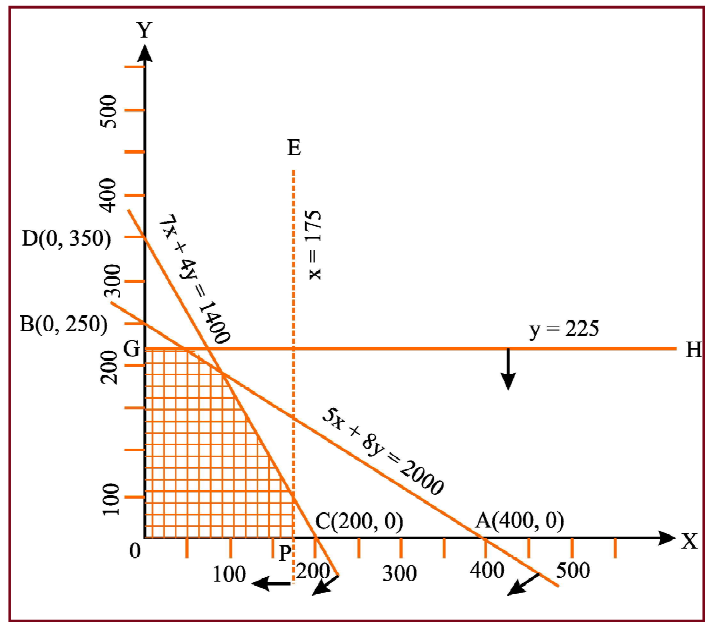

Example 10: Draw the graphs of the following linear inequalities:

$$\begin{aligned} x + y &\geq 1, & 7x + 9y &\leq 63, \\ y &\leq 5, & x &\leq 6, & x &\geq 0, & y &\geq 0. \end{aligned}$$

and mark the common region.

Solution: $x + y = 1$; $\frac{x}{1} \left| \frac{1}{0} \right| \frac{0}{1}$; $7x + 9y = 63$, $\frac{x}{9} \left| \frac{9}{0} \right| \frac{0}{7}$.

We plot the line $AB(x + y = 1)$, $CD(y = 5)$, $EF(x = 6)$,
 $DE(7x + 9y = 63)$.

Given inequalities are shown by arrows.

Common region $ABCDEF$ is the shaded region.

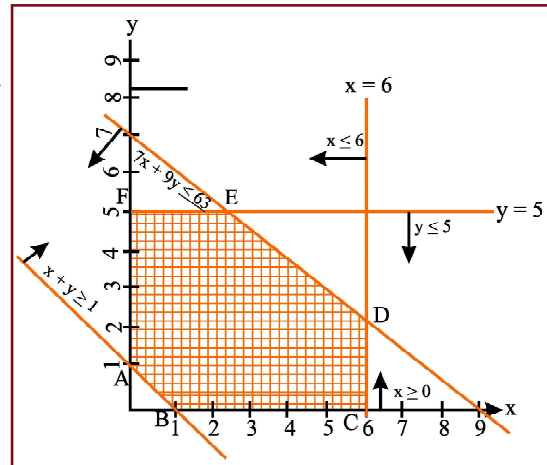

Example 11: Two machines (I and II) produce two grades of plywood, grade A and grade B. In one hour of operation machine I produces two units of grade A and one unit of grade B, while machine II, in one hour of operation produces three units of grade A and four units of grade B. The machines are required to meet a production schedule of at least fourteen units of grade A and twelve units of grade B. Express this using linear inequalities and draw the graph.

Solution: Let the number of hours required on machine I be x and that on machine II be y . Since in one hour, machine I can produce 2 units of grade A and one unit of grade B, in x hours it will produce $2x$ and x units of grade A and B respectively. Similarly, machine II, in one hour, can produce 3 units of grade A and 4 units of grade B. Hence, in y hours, it will produce $3y$ and $4y$ units Grade A & B respectively.

The given data can be expressed in the form of linear inequalities as follows:

$$2x + 3y \geq 14 \text{ (Requirement of grade A)}$$

$$x + 4y \geq 12 \text{ (Requirement of grade B)}$$

Moreover x and y cannot be negative, thus $x \geq 0$ and $y \geq 0$

Let us now draw the graphs of above inequalities. Since both x and y are positive, it is enough to draw the graph only on the positive side.

The inequalities are drawn in the following graph:

For $2x + 3y = 14$,

x	7	0
y	0	4.66

For $x + 4y = 12$,

x	0	12
y	3	0

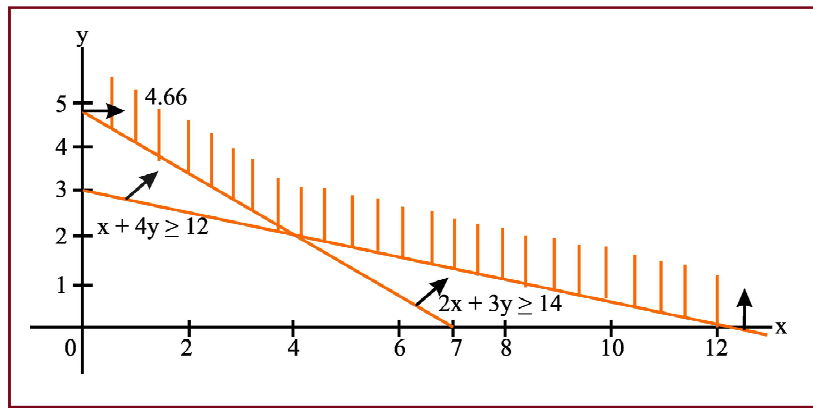

In the above graph we find that the shaded portion is moving towards infinity on the positive side. Thus the result of these inequalities is unbounded.

EXERCISE: 3 (A)

Choose the correct answer/answers

- 1 (i) An employer recruits experienced (x) and fresh workmen (y) for his firm under the condition that he cannot employ more than 9 people. x and y can be related by the inequality
 - (a) $x + y \neq 9$
 - (b) $x + y \leq 9$
 - (c) $x + y \geq 9$
 - (d) none of these
- (ii) On the average experienced person does 5 units of work while a fresh one 3 units of work daily but the employer has to maintain an output of at least 30 units of work per day. This situation can be expressed as
 - (a) $5x + 3y \leq 30$
 - (b) $5x + 3y > 30$
 - (c) $5x + 3y \geq 30$
 - (d) none of these
- (iii) The rules and regulations demand that the employer should employ not more than 5 experienced hands to 1 fresh one and this fact can be expressed as
 - (a) $y \geq x/5$
 - (b) $5y \leq x$
 - (c) $5y \geq x$
 - (d) none of these

(iv) The union however forbids him to employ less than 2 experienced person to each fresh person. This situation can be expressed as

- (a) $x \leq y/2$ (b) $y \leq x/2$ (c) $y \geq x/2$ (d) $x > 2y$

(v) The graph to express the inequality $x + y \leq 9$ is

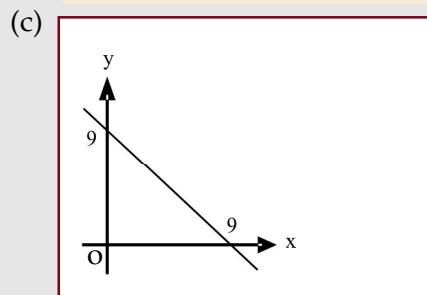
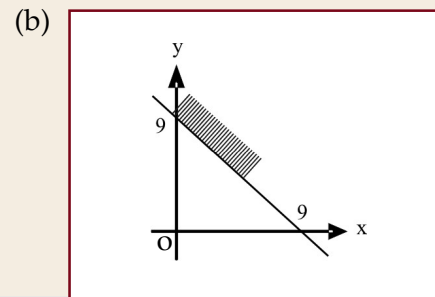
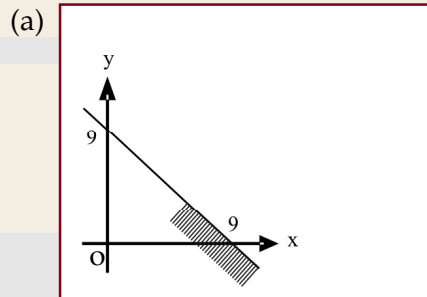

(d) none of these

(vi) The graph to express the inequality $5x + 3y \geq 30$ is

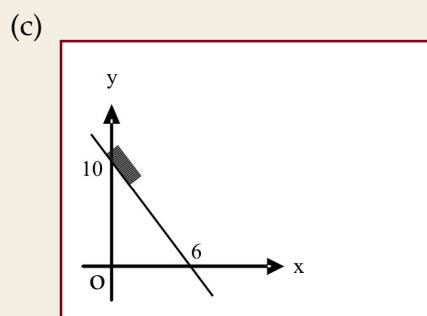
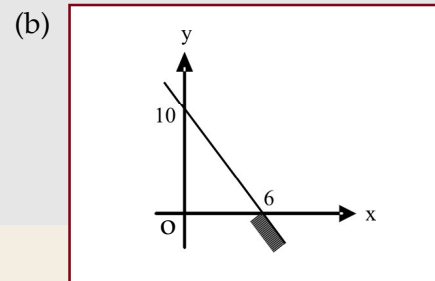
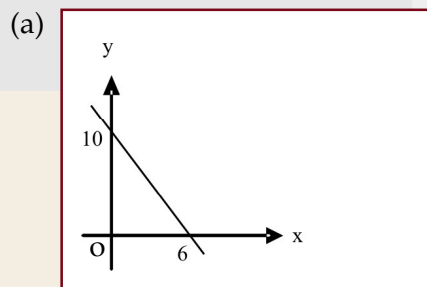

(d) none of these

(vii) The graph to express the inequality $y \leq \left(\frac{1}{2}\right)x$ is indicated by

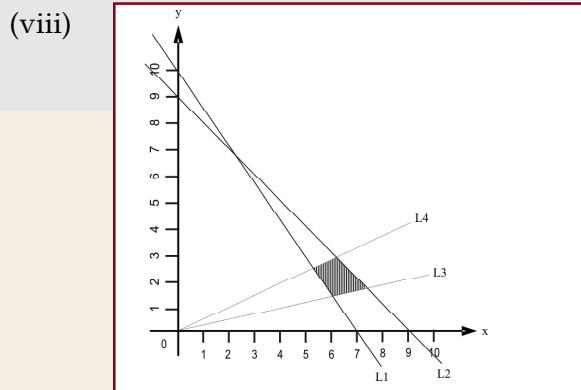
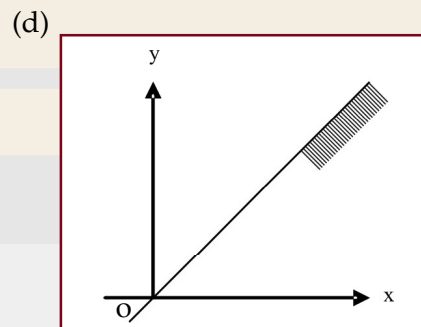
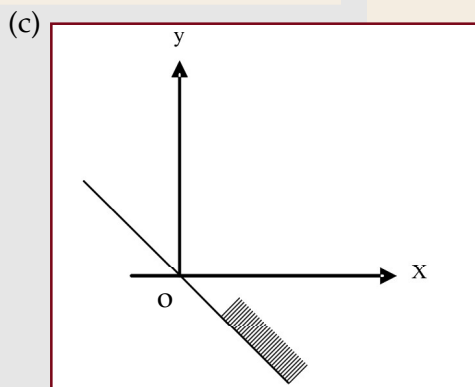
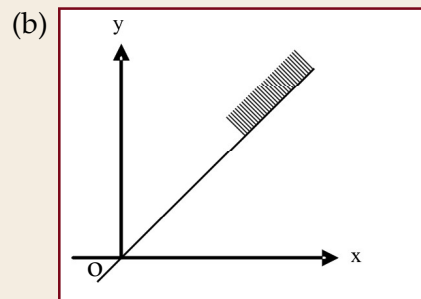
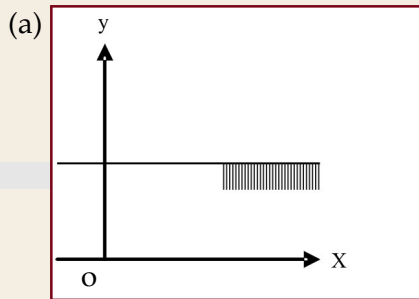

L1 : $5x + 3y = 30$ L2 : $x + y = 9$ L3 : $y = x/3$ L4 : $y = x/2$

The common region (shaded part) shown in the diagram refers to

- (a) $5x + 3y \leq 30$ (b) $5x + 3y \geq 30$ (c) $5x + 3y \geq 30$ (d) $5x + 3y > 30$ (e) None of these
- | | | | |
|----------------|----------------------|----------------------|----------------------|
| $x + y \leq 9$ | $x + y \leq 9$ | $x + y \geq 9$ | $x + y < 9$ |
| $y \leq 1/5 x$ | $y \geq x/3$ | $y \leq x/3$ | $y \geq 9$ |
| $y \leq x/2$ | $y \leq x/2$ | $y \geq x/2$ | $y \leq x/2$ |
| | $x \geq 0, y \geq 0$ | $x \geq 0, y \geq 0$ | $x \geq 0, y \geq 0$ |

2. A dietitian wishes to mix together two kinds of food so that the vitamin content of the mixture is at least 9 units of vitamin A, 7 units of vitamin B, 10 units of vitamin C and 12 units of vitamin D. The vitamin content per Kg. of each food is shown below:

	A	B	C	D
Food I:	2	1	1	2
Food II:	1	1	2	3

Assuming x units of food I is to be mixed with y units of food II the situation can be expressed as

- | | | | |
|---------------------|----------------------|---------------------|----------------------|
| (a) $2x + y \leq 9$ | (b) $2x + y \geq 30$ | (c) $2x + y \geq 9$ | (d) $2x + y \geq 9$ |
| $x + y \leq 7$ | $x + y \leq 7$ | $x + y \geq 7$ | $x + y \geq 7$ |
| $x + 2y \leq 10$ | $x + 2y \geq 10$ | $x + y \leq 10$ | $x + 2y \geq 10$ |
| $2x + 3y \leq 12$ | $x + 3y \geq 12$ | $x + 3y \geq 12$ | $2x + 3y \geq 12$ |
| $x > 0, y > 0$ | | | $x \geq 0, y \geq 0$ |

3. Graphs of the inequations are drawn below :

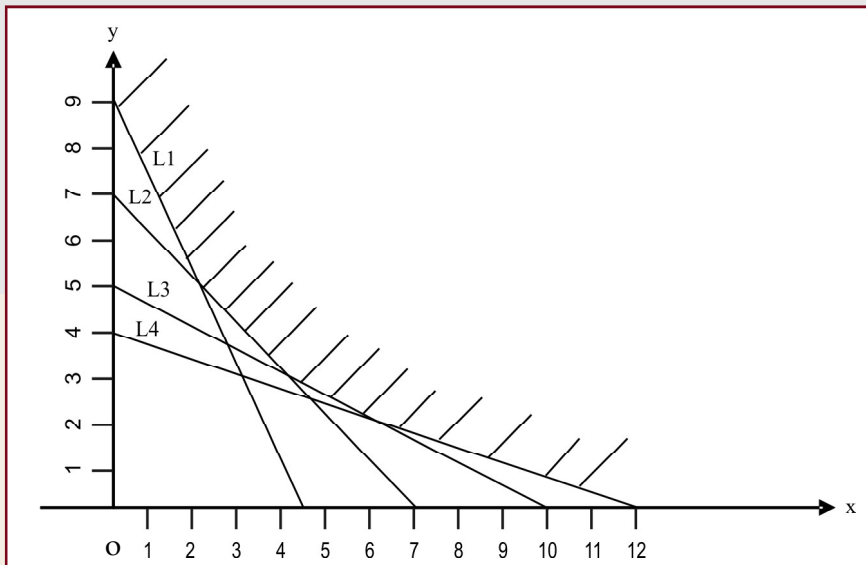

L1 : $2x + y = 9$ L2 : $x + y = 7$ L3 : $x + 2y = 10$ L4 : $x + 3y = 12$

The common region (shaded part) indicated on the diagram is expressed by the set of inequities

- | | | | |
|---------------------|---------------------|----------------------|-------------------|
| (a) $2x + y \leq 9$ | (b) $2x + y \geq 9$ | (c) $2x + y \geq 9$ | (d) none of these |
| $x + y \geq 7$ | $x + y \leq 7$ | $x + y \geq 7$ | |
| $x + 2y \geq 10$ | $x + 2y \geq 10$ | $x + 2y \geq 10$ | |
| $x + 3y \geq 12$ | $x + 3y \geq 12$ | $x + 3y \geq 12$ | |
| | | $x \geq 0, y \geq 0$ | |

4. The common region satisfied by the inequalities L1: $3x + y \geq 6$, L2: $x + y \geq 4$, L3: $x + 3y \geq 6$, and L4: $x + y \leq 6$ is indicated by

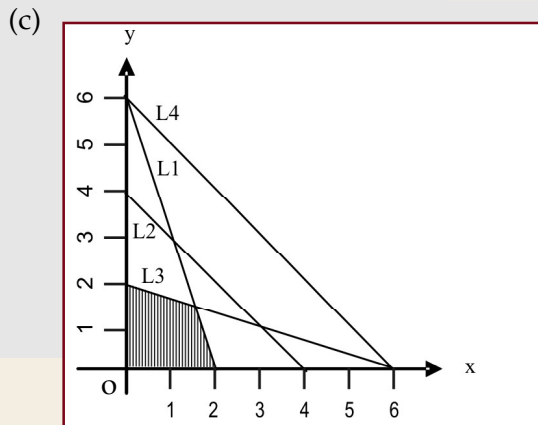
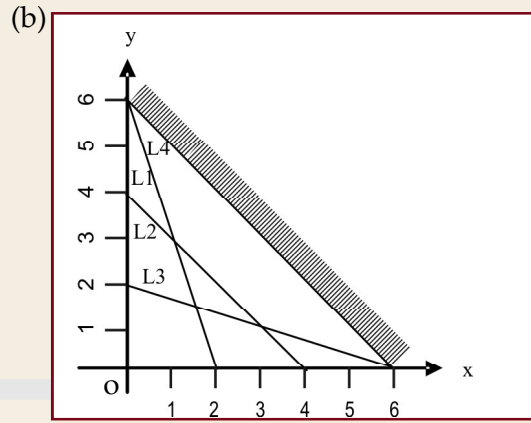
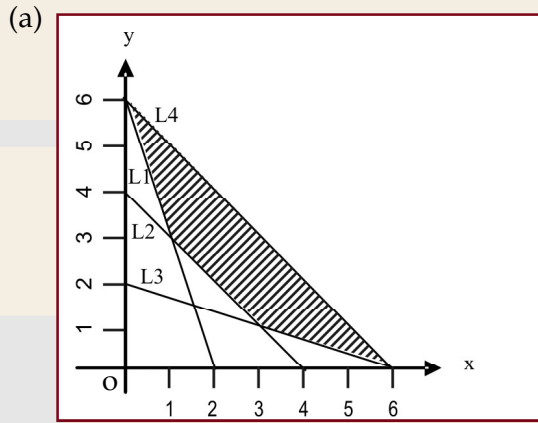

(d) none of these

5. The region indicated by the shading in the graph is expressed by inequalities

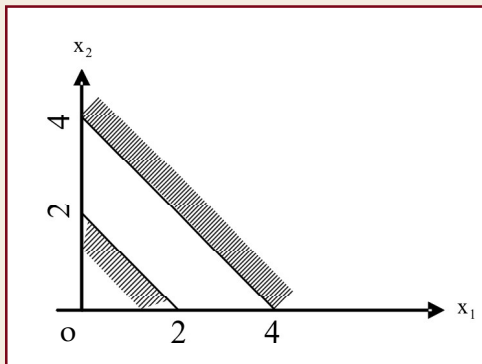

- (a) $x_1 + x_2 \leq 2$ (b) $x_1 + x_2 \leq 2$ (c) $x_1 + x_2 \geq 2$ (d) $x_1 + x_2 \leq 2$
 $2x_1 + 2x_2 \geq 8$ $x_2 x_1 + x_2 \leq 4$ $2x_1 + 2x_2 \geq 8$ $2x_1 + 2x_2 > 8$
 $x_1 \geq 0, x_2 \geq 0,$

6. (i) The inequalities $x_1 \geq 0, x_2 \geq 0,$ are represented by one of the graphs shown below:

(a)

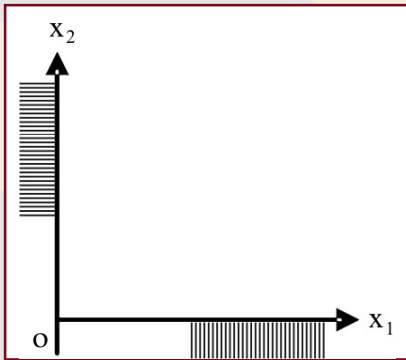

(b)

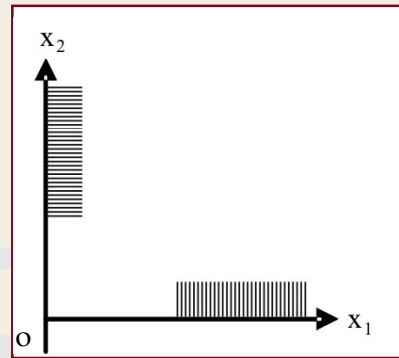

(c)

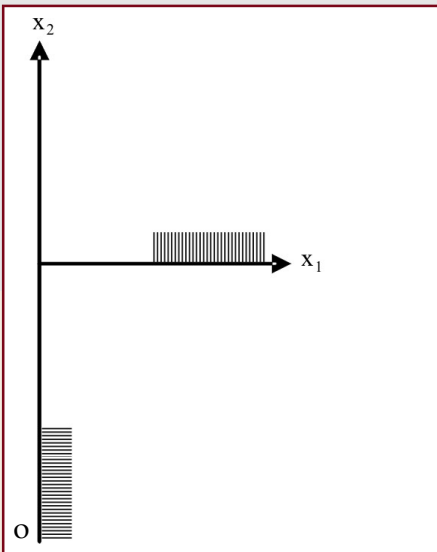

(d)

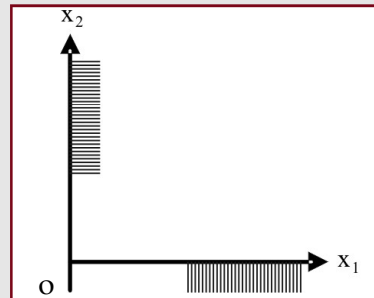

(ii)

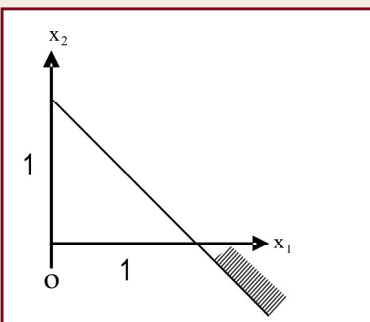

The region is expressed as

- (a) $x_1 - x_2 \geq 1$
 (b) $x_1 + x_2 \leq 1$
 (c) $x_1 + x_2 \geq 1$
 (d) none of these

(iii) The inequality $-x_1 + 2x_2 \leq 0$ is indicated on the graph as

(a)

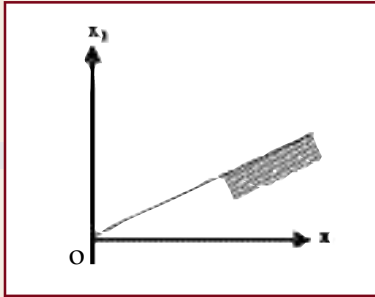

(b)

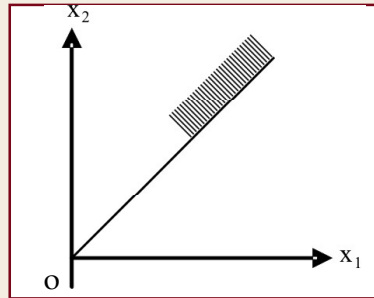

(c)

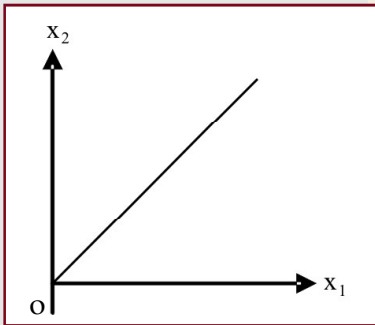

(d) none of these

7.

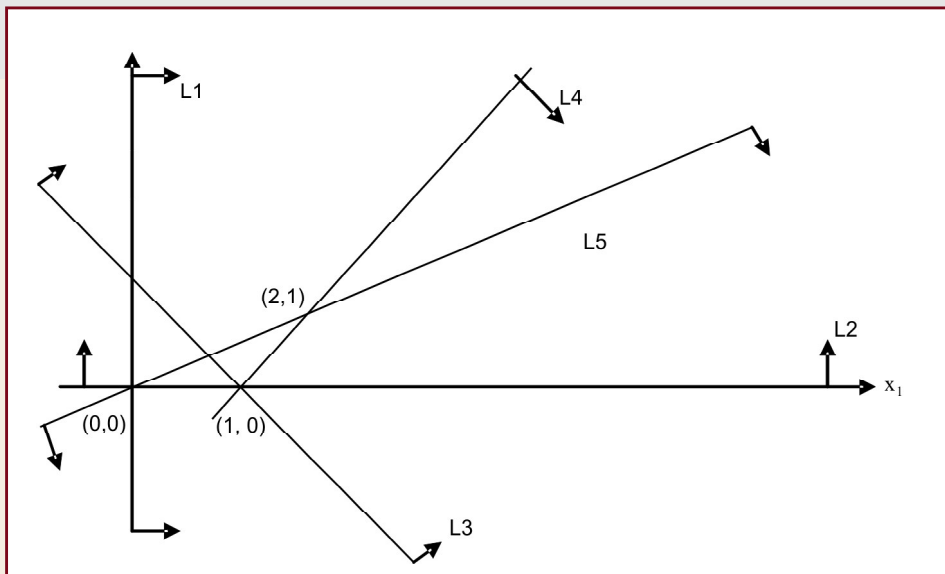

The common region indicated on the graph is expressed by the set of five inequalities

- (a) $L1 : x_1 \geq 0$ (b) $L1 : x_1 \geq 0$ (c) $L1 : x_1 \leq 0$ (d) None of these
 $L2 : x_2 \geq 0$ $L2 : x_2 \geq 0$ $L2 : x_2 \leq 0$
 $L3 : x_1 + x_2 \leq 1$ $L3 : x_1 + x_2 \geq 1$ $L3 : x_1 + x_2 \geq 1$
 $L4 : x_1 - x_2 \geq 1$ $L4 : x_1 - x_2 \geq 1$ $L4 : x_1 - x_2 \geq 1$
 $L5 : -x_1 + 2x_2 \leq 0$ $L5 : -x_1 + 2x_2 \leq 0$ $L5 : -x_1 + 2x_2 \leq 0$

8. A firm makes two types of products : Type A and Type B. The profit on product A is ₹ 20 each and that on product B is ₹ 30 each. Both types are processed on three machines M1, M2 and M3. The time required in hours by each product and total time available in hours per week on each machine are as follows:

Machine	Product A	Product B	Available Time
M1	3	3	36
M2	5	2	50
M3	2	6	60

The constraints can be formulated taking x_1 = number of units A and x_2 = number of unit of B as

- (a) $x_1 + x_2 \leq 12$ (b) $3x_1 + 3x_2 \geq 36$ (c) $3x_1 + 3x_2 \leq 36$ (d) none of these
 $5x_1 + 2x_2 \leq 50$ $5x_1 + 2x_2 \leq 50$ $5x_1 + 2x_2 \leq 50$
 $2x_1 + 6x_2 \leq 60$ $2x_1 + 6x_2 \geq 60$ $2x_1 + 6x_2 \leq 60$
 $x_1 \geq 0, x_2 \geq 0$ $x_1 \geq 0, x_2 \geq 0$

9. The set of inequalities $L1: x_1 + x_2 \leq 12$, $L2: 5x_1 + 2x_2 \leq 50$, $L3: x_1 + 3x_2 \leq 30$, $x_1 \geq 0$, and $x_2 \geq 0$ is represented by

(a)

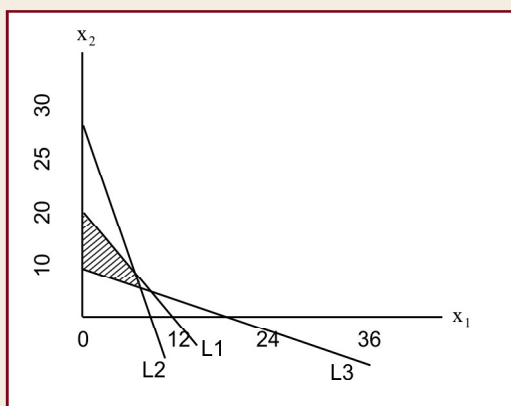

(b)

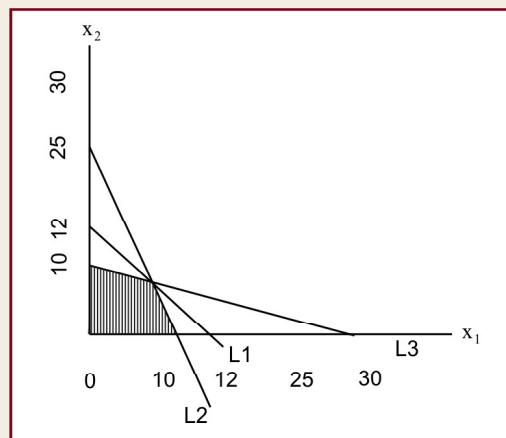

(c)

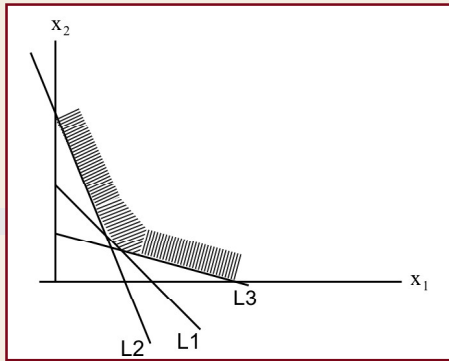

(d) none of these

10. The common region satisfying the set of inequalities $x \geq 0, y \geq 0, L1: x+y \leq 5, L2: x+2y \leq 8$ and $L3: 4x+3y \geq 12$ is indicated by

(a)

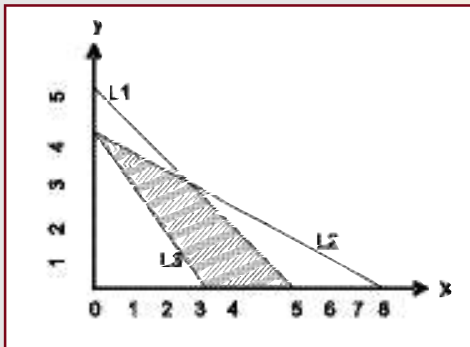

(b)

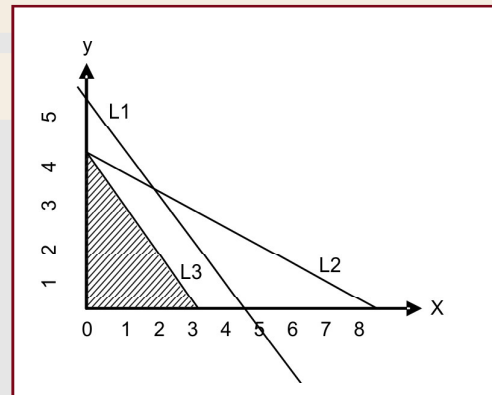

(c)

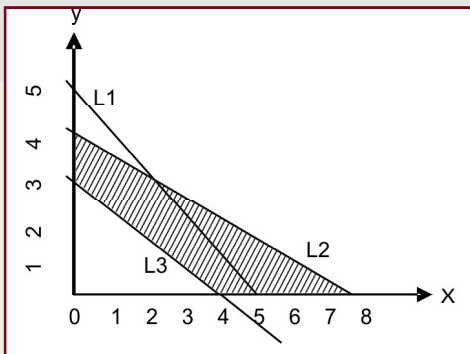

(d) none of these



SUMMARY

- ◆ Any linear function that involves an inequality sign is a linear inequality. It may be of one variable, or, of more than one variable. Simple example of linear inequalities are those of one variable only; viz., $x > 0, x < 0$.
- ◆ The values of the variables that satisfy an inequality are called the *solution space*, and is abbreviated as S.S. The solution spaces for (i) $x > 0$, (ii) $x \leq 0$ are shaded in the diagrams, by using deep lines.
- ◆ Linear inequalities in two variables may be solved easily by extending our knowledge of straight lines.

ANSWERS

1. (i) (b) (ii) (c) (iii) (a or c) (iv) (b) (v) (a) (vi) (c) (vii) (d) (viii) (b)
2. (d) 3. (c) 4. (a) 5. (a) 6. (i) (b) (ii) (c) (iii) (a)
7. (b) 8. (c) 9. (b) 10. (a)

ADDITIONAL QUESTION BANK

1. On solving the inequalities $2x + 5y \leq 20$, $3x + 2y \leq 12$, $x \geq 0, y \geq 0$, we get the following situation
(a) $(0, 0), (0, 4), (4, 0)$ and $(\frac{20}{11}, \frac{36}{11})$ (b) $(0, 0), (10, 0), (0, 6)$ and $(\frac{20}{11}, \frac{36}{11})$
(c) $(0, 0), (0, 4), (4, 0)$ and $(2, 3)$ (d) $(0, 0), (10, 0), (0, 6)$ and $(2, 3)$
2. On solving the inequalities $6x + y \geq 18$, $x + 4y \geq 12$, $2x + y \geq 10$, we get the following situation
(a) $(0, 18), (12, 0), (4, 2)$ and $(2, 6)$
(b) $(3, 0), (0, 3), (4, 2)$ and $(7, 6)$
(c) $(5, 0), (0, 10), (4, 2)$ and $(7, 6)$
(d) $(0, 18), (12, 0), (4, 2), (0, 0)$ and $(7, 6)$

ANSWERS

1. (a) 2. (a)